

**GASFLOW**  
**ALFA SERIES REGULATORS**  
**(2.5 - 6 - 10 - 16 - 25 - 30 - 50 m<sup>3</sup>/h)**



**ALFA - Series** regulators are two-stage self-operated pressure regulators for domestic and low capacity commercial use for NG, LPG, Town Gas, Methane, Air (For other gaseous on request. Please consider density correction factor for gases other than NG for nominal capacity selection). Equipped with slam shut mechanism against increase and decrease in outlet pressure (**adjustable OPSO/UPSO**). The discharge of the internal relief valve can be conveyed outside in case of installation in closed rooms or underground installations.

**ALFA - Series (2.5m<sup>3</sup>/h→ 50m<sup>3</sup>/h)** can be used at outlet pressure between **9→500 mbar** by configuring properly of the regulator bill of materials.

**ALFA - Series** regulators are designed to be installed outdoor/indoor , wall mounted/underground box with different inlet/outlet configurations (**Angle, Inline, U, T, Q**), in individual domestic gas systems and meters

Inlet and outlet connections can be customized according to customer needs and standards.

Thanks to smart engineering to achieve high reliability and accuracy in regulation yielding measurement correction errors to keep at minimum level.

All service regulators are produced according to the international norms and standards such as EN88-2 and TS 10624.

**Two Stage Service Regulator with OPSO/UPSO Safety Shut-Off Valve**

	DESCRIPTION	STANDARD	OPTION	CUSTOMIZABLE FEATURE
<b>MAIN FEATURES</b>	MAX. INLET PRESSURE-Pe, (bar)	6	-	Other Values
	OUTLET PRESSURE -Po, (mbar)	21	300	9 - 500
	INLET CONNECTION	¾"	½", 1", 1 ¼"	Others
	OUTLET CONNECTION	1 ¼"	1", 1 ¼", 1 ½", 2"	Others
	RE-ARMING	SSV	-	-
	INLET FILTER	Brass Mesh	Stainless Steel	Different Materials
	INLET TEST POINT	-	Yes	-
	OUTLET TEST POINT	-	Yes	-
	SURFACE PREPARATION	Sand Blasted	Colour Codes	Coating
	APPLICABLE STANDARTS	EN88-2	NF, TS 10624	Others
	FUNCTIONAL TEST RATIO (%)	100	-	Additional tests

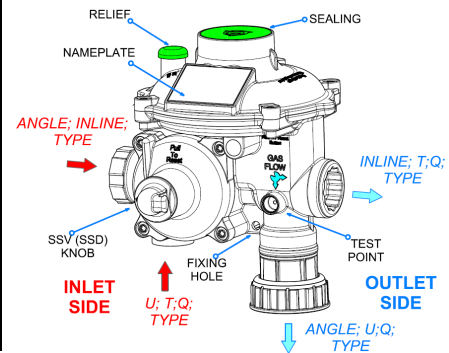

<b>SAFETY</b>	OPSO WITH RELIEF	Yes	No	-
	OPSO WITH SSV	Yes	-	-
	UPSO WITH SSV	Yes	-	-
	SEALING	Special Design	2 <sup>nd</sup> Stg cover	Different Locations

<b>OPERATING CHARACTERISTICS</b>	APPLICATION SPACE	Outdoor	Indoor <sup>(*)</sup>	-
	APPLICATION TYPE	Wall Mounted	Underground	-
	ASSEMBLY CONFIGURATION	Angle, Inline, U, T, Q	-	-
	ACCURACY CLASS-AC/RG (%)	±10	±5	Intermediate Values
	LOCK-UP ACCURACY CLASS -SG(%)	20	10	Between 10-20%
	HYSTRESIS (%)	10	-	-
	EXCESS FLOW RANGE (m <sup>3</sup> /h)	Qn*(110-150)%	Qn*(120-150)%	-
	LOCK-UP ZONE-SZ (%)	10	-	Other values
	RELIEF TOLERANCE (%)	±10	-	Other values
	AMBIENT TEMPERATURE (°C)	-20 : 60 (EN88-2)	-10 : 50 (TS 10624)	Arctic
	FLUID TYPE	NG, LPG, Town Gas, Methane, Air	-	Others

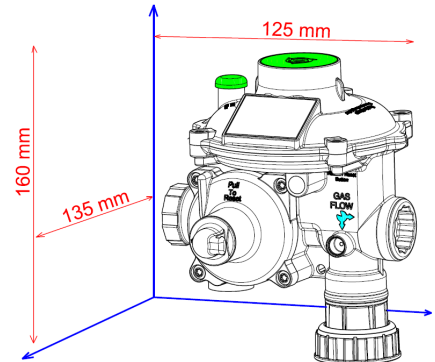

(\*) The discharge of the internal relief valve must be conveyed outside in case of installation in closed rooms or underground installations

<b>MATERIALS</b>	BODY, COVERS	AL ( TS EN 1706 )	ZAMAK-5	Other ZAMAK types
	SPRINGS	Carbon Steel	Stainless Steel	Other Materials
	ORIFICES	CuZn39Pb3	-	Other Materials
	DIAPHRAGMS, ORINGS	NBR (EN549)	-	-
	CONNECTION PARTS	CuZn40Pb2, AL	-	Other Materials
	INTERNALS	Brass, Al, ZAMAK, POM, PA	-	Other Materials



Images and dimensions are for reference purposes and may vary depending on the preferences made. **GASFLOW TEKNOLOJİ LİMİTED ŞİRKETİ** reserves the right to change its product models and technical information without prior notice

- INLET PRESSURE
- OUTLET PRESSURE
- INTERMEDIATE PRESSURE
- ATMOSPHERIC PRESSURE

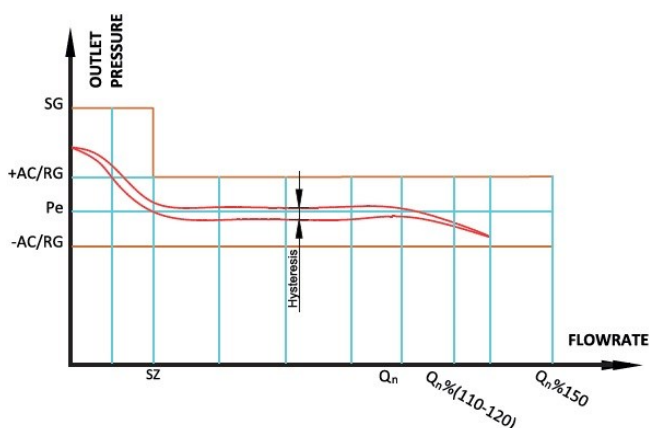
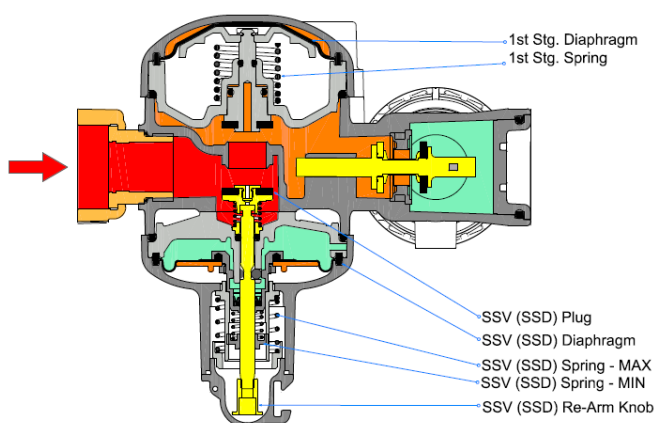
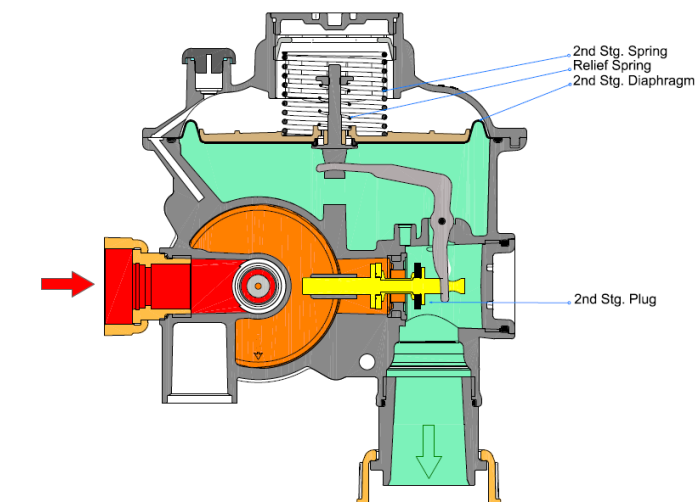

FLUID	d
AIR	1
TOWN GAS	0,44
BUTANE	2,01
PROPANE	1,53
ETHANE	1,05
METHANE	0,55

$$Q_{\text{Natural Gas}} * \sqrt{\frac{176,68}{d * (273 + T)}} = Q_{\text{Other Gas}}$$

d = Relative density other than natural gas

T = Ambient temperature [°C]

Note: Non-exist / intermediate capacity values can be possible on request !

## GENERAL

The primary function of a spring loaded two stage gas regulator is to match the flow of gas through the regulator to the demand for gas placed upon the system. At the same time, the regulator must maintain the system pressure within certain acceptable limits.

Since the regulator's job is to modulate the flow of gas into the system, restricting element (**1<sup>st</sup> and 2<sup>nd</sup> stage plug**) that will fit into the flow stream is essential and needed to provide a variable restricted modulation of the flow of gas through the regulator.

In order to cause restricting element to vary, loading element (**1<sup>st</sup> Stage , 2<sup>nd</sup> Stage, relief , Over Pressure Shut Off (OPSO) // Under Pressure Shut Off (UPSO) springs**) is needed which can apply the required force limits to the restricting element. And measuring element (**1<sup>st</sup> and 2<sup>nd</sup> , Slam Shut Valve (SSV) diaphragm**) which tells regulator when flow has been perfectly matched and characterized to desired values is needed.

Outlet pressures over than set value is managed by **built-in relief valve, OPSO valve**, whereas below than outlet set value is managed by **UPSO valve in SSV** for secure operation.

**Built-in relief valve** triggers when set value is reached to compensate outlet pressure increase such as thermal expansion in downstream even appliances are off.

**OPSO/UPSO SSV** is a safety device of which its restoration takes place manually prevents gas flow if anomalous downstream pressure conditions (Tripping of maximum/minimum outlet pressure) do occur.

When the spring loaded two-stage SSV gas regulator is designed and produced with the above elements, it has a typical regulator performance curve as in the graph.

## OPERATION

Making sure all the utility /appliance connections are closed securely, by opening regulator upstream valve slightly and slowly, gas with inlet pressure initially flows through the inlet filter and comes in front of the first stage. Gently pull **SSV re-arm knob** to let the gas from **SSV plug** until conveying gas under **2<sup>nd</sup> Stg Diaphragm and SSV Diaphragm** where pressure is reduced to the desired outlet value. Downstream pressure must be observed whether it is at desired values.

After completing the procedure release push button and SSV re-arm knob observing SSV re-arm knob still stays pulled.